

LINCOLN

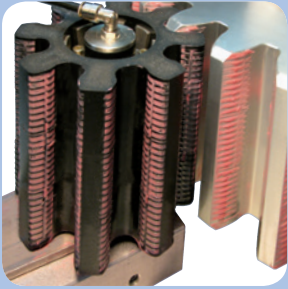

Automatic lubrication systems for precise friction control

Helping maintain and sustain the wind energy market



Why use automatic lubrication?

A lack of proper lubrication can bring your valuable equipment to a standstill. Vibration, high mechanical loads, contamination and moisture are all threats to the life of your bearings.

Proper lubrication protects your machine and extends the life of its critical components. With a Lincoln automatic lubrication system, you will lengthen bearing life by delivering frequent, small amounts of grease to each bearing while the machine is running.

With manual, uncontrolled lubrication, each bearing runs the risk of receiving too much or too little grease resulting in wasted grease or friction and wear. In addition, manual lubrication is tedious, expensive and often is not even possible due to the location of hard-to-reach lube points.

Controlled, exact amounts of lubricant delivered frequently keep bearings perfectly coated enabling them to perform to capacity.

Precisely apply small amounts of lubricant frequently

Lubricant volume per lube event

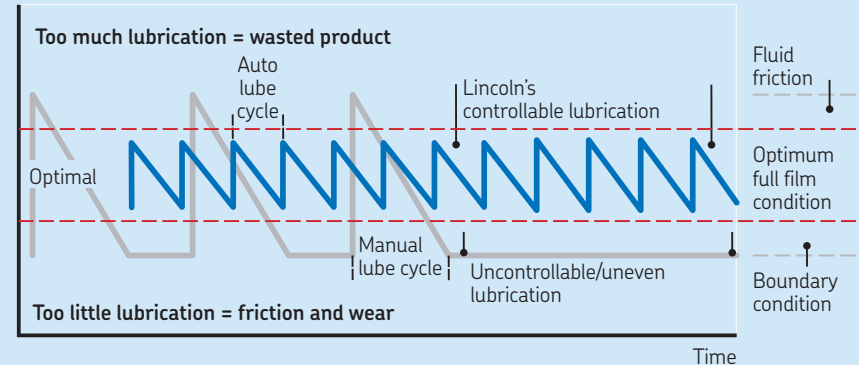

Benefits of automatic lubrication

- Lower costs for repairs, spare parts and lubricant
- Improved operating times; less costly downtime
- Longer maintenance intervals – one year or longer
- Greater bearing life thanks to regular, exact amounts of lubricant
- Reduced safety issues associated with hard-to-reach lubrication points
- Added corrosion protection from the elements
- No wasted lubrication

CAUTION

For all systems described in this brochure, see important product usage information on the back cover.

A solution for every wind turbine application

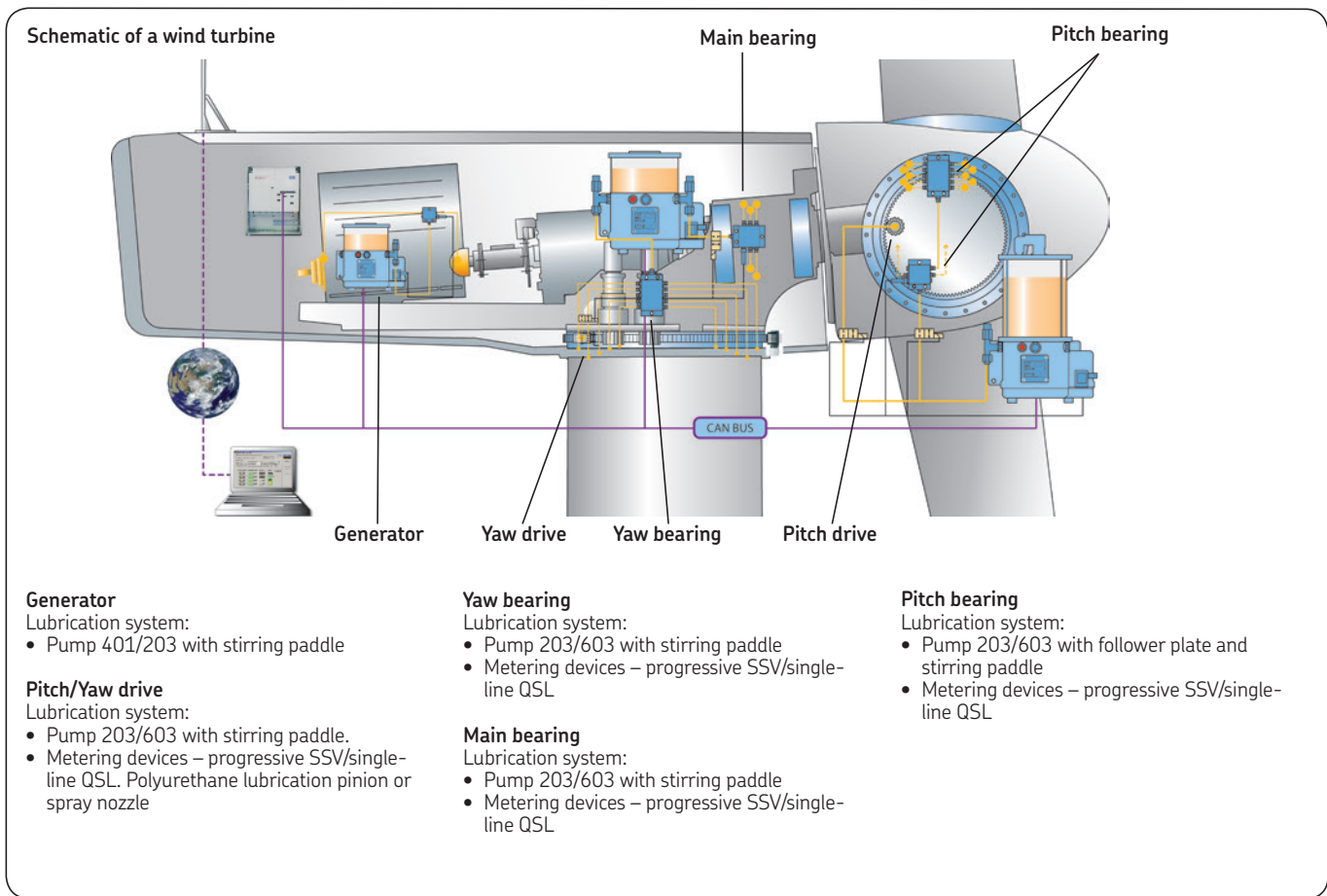

Regardless of the wind turbine's design, several bearings and drives require lubrication. The proper lubrication system simplifies service tasks, extends the service interval and protects from atmospheric conditions.

Expensive, unplanned repairs and downtime are avoided and the life span of the wind turbine is increased.

Lincoln offers lubrication system solutions that are tailored for applications on blade bearings, main bearing, yaw bearings and generators.

In addition, our product range includes spray lubrication systems and lubrication pinions for the lubrication of gear drives.

The lubricant is always reliably and consistently delivered from the pump to the lubrication point – either by means of progressive metering devices or single-line metering devices.

QLS 401 compact system

The QLS 401 is a complete lubrication system for grease that includes all necessary monitoring and control functions. All components including an internal overpressure valve are part of the complete package. The comprehensive list of standard features is a remarkable characteristic of the QLS 401. The integrated, all-in-one system concept reduces installation time and costs.

A newly enhanced stirring paddle in the reservoir prevents grease separation – even with long service intervals.

The QLS 401 is designed for all industrial and mobile applications. Up to 18 lubrication points can reliably be supplied directly from the pump and monitored.

Multifunctional

The QLS 401 is versatile. An integrated circuit board optimally controls the pause time and the pump cycles for a regular supply of lubricant. All settings are performed with ease via the keypad. Settings and messages are shown on the built-in LED display.

The QLS 401 is also available in a “key lock” version that locks the programming function.

Sturdy

The QLS 401 is shock and vibration proof and operates reliably, even when exposed to severe operating conditions such as temperatures ranging from –25 to +70 °C or high-pressure wash-downs (IP6K9K, NEMA 4 protection).

Compact

The QLS 401 is a high-pressure grease pump with a controller and monitoring, a function display and a divider block. All system components and all the functions that are needed to lubricate at a professional level are included.



Also available in a “key lock” version that locks the programming function.



System benefits

- 1 and 2 litre reservoir capacity
- Small compact, ready-to-install package
- Space requirements – 230 x 230 x 215 mm
- Integrated controller with monitoring – optionally without controller
- Low-level control, optional
- Integrated display and keypad
- Easy refilling – please inquire for further information
- Built-in over-pressure valve with return
- Available in 12 or 24 VDC as well as 120 VAC, 60 Hz and 230 VAC, 50/60 Hz
- Attached divider block – optionally with external divider block
- Internal outlet lubricant return possibility
- Large spectrum of usable lubricants – for multipurpose grease up to NLGI 2

Quickclub progressive system

The new generation of Quickclub systems now offers the following enhancements and product characteristics – standard:

- The new material of the pump housing is extremely weather-resistant and not susceptible to UV rays
- The pump housing has a larger filling port for easy filling of the reservoir
- The strengthened stirring paddle is now available in the standard version. This provides a good lubricant mixing even at extreme sub-zero temperatures
- The stronger spring of the pump element is now used for all pump elements thus providing an improved return of the piston
- The filling adapter has a fixed, “captive” cap

The Lincoln Quickclub pump is the standard lubrication pump for all applications. Quickclub pumps supply small to mid-sized machines and systems with up to 250 lube points.



Inquire about the special versions of our Quickclub pumps

- Without PCB
- With microprocessor monitoring
- With adjustable run / pause times
- With QuickData data logger for complete system diagnosis



System benefits

No corrosion of the light-weight pump housing which is made of heavy-duty, fiber-reinforced resin:

- The pump motor is protected against damage and moisture (IP6K9K)
- 2, 4, 8 and 15 litre reservoir (Optional with filling from the top and a lockable lid)
- Various pump elements with fixed or variable output
- Over-pressure valve – also equipped with an indicator and reservoir return
- Fully-automated option via integrated PCB

- Optional integrated display, touch pad and data logger function for the storage of important information such as operating time, faults or blockages and low-level
- Installation can be performed with threaded or 350 bar rated Quicklinec plug-in type fittings

Progressive lubricant metering devices

SSV, SSVD and variants

- Block form – less prone to failure
- Leaks are avoided
- A higher operating pressure ensures reliability – even at minus temperatures
- Easy to monitor
- Error-free exchange as complete blocks are exchanged always. Mistakes in connecting or in settings are avoided.

SSV

SSV are piston metering devices that reliably divide the incoming lubricant in predetermined individual quantities. Lincoln progressive metering devices do not have fault-prone rubber seals. As a result, they can be used with high back-pressures, and they are ideally suitable for a wide range of temperatures. The maximum operating pressure is 350 bar.

SSV metering devices are available with 6 to 22 outlets in stainless steel with with 6 to 14 outlets.

SSVD

Easy setting of the lubricant quantity via Lincoln metering screw technology

- Progressive metering device in solid-block form – with flexible metering
- Wide range of metering – leaves nothing to be desired
- Easy to alter metered quantities via metering screws – no disassembly and reassembly of metering device segments – also possible to do when the metering device is already fitted
- Special corrosion-resistant version

SSVD metering devices are adjustable per outlet pair, thus enabling a much better match to the optimum lubricant requirements. The metering occurs within the metering block via metering screws that are available in 10 different sizes.

SSVD metering devices are available in the standard 6 to 22 outlets.

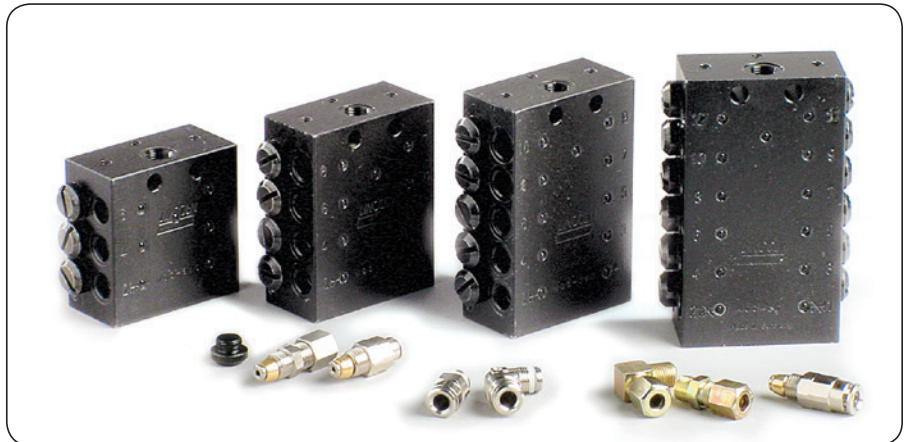

Metering screws per outlet pair are available in ten sizes – 0.08; 0.14; 0.2; 0.3; 0.4; 0.6; 0.8; 1.0; 1.4 and 1.8 cm³ per outlet and stroke.

SSVD-V1 metering devices with internally connected outlet numbers 1 and 2 allow for additional better matching of applications with an uneven number of lube points.

SSVE and SSVDE Lubricant Metering Devices

Lincoln SSV and SSVD metering devices are also available in an “E” version with an emergency lubrication fitting on the front face of the block.

The “E” metering devices are ideal for single-nipple lubrication systems. The additional, easy to access lubrication fitting simplifies service and trouble-shooting tasks as a manual grease gun can be used. Also, additional emergency over ride greasing is possible without having to change the system configuration.



Single line lubrication system

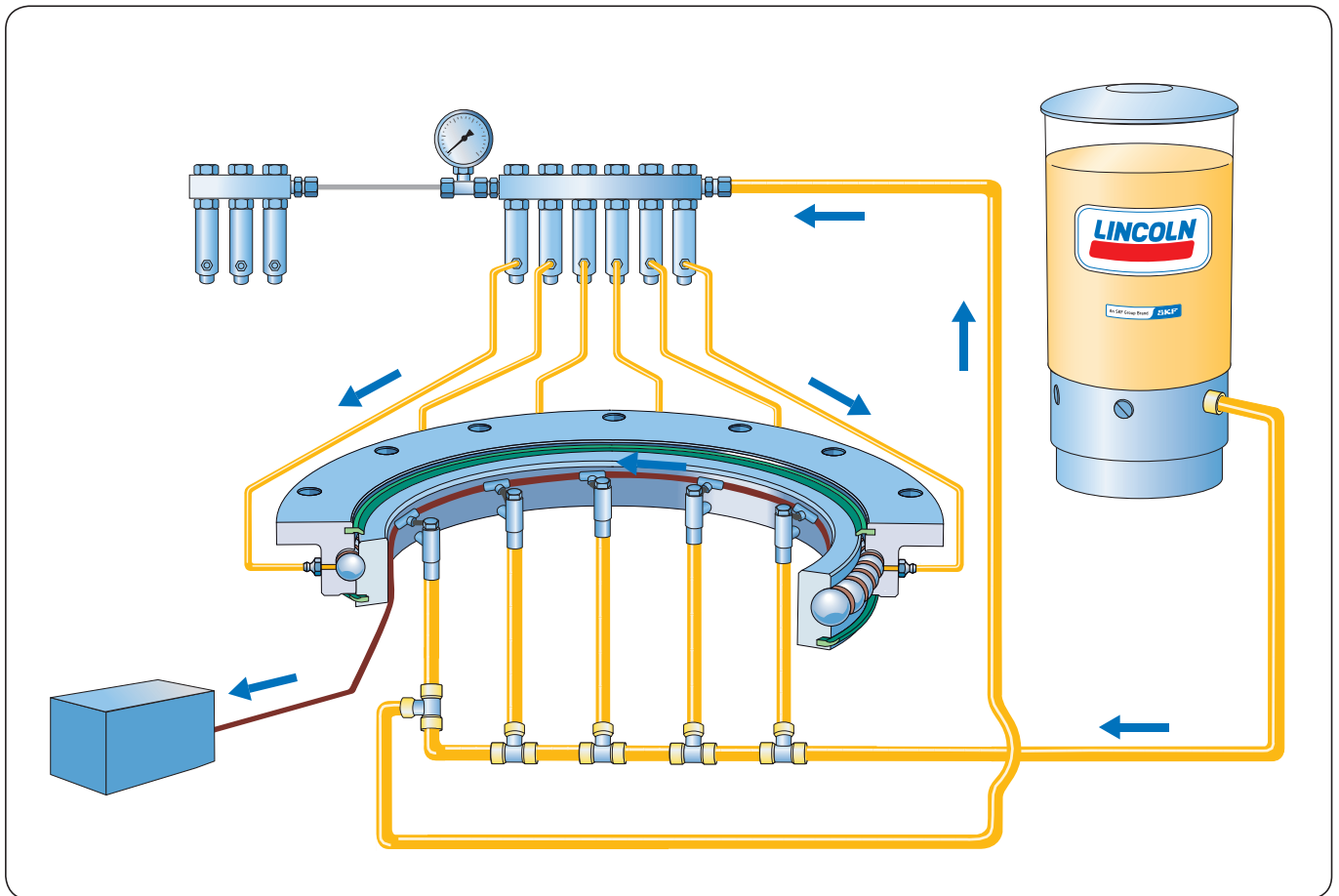

Pump 603S, QSL/SL injectors and SE1 suction elements for used lubricants. Lincoln single-line systems can be integrated with SE1 suction elements for the collection of used lubricant. The recovered lubricant can be used for the lubrication of open gears. As a result, this system offers a complete recycling circuit of the lubricant.

Functional principle

The lubrication system consists of a pump 603S and direct operating QSL/SL injectors. The injectors supply lubricant under full pump pressure (direct operating) to the individual lubrication points. The max. working pressure is max. 300 bar. NLGI 2 lubricants can be pumped even at below zero temperatures without problems.

The pumps are designed to internally combine the lubricant of 3 pump elements. This provides sufficient output performance to supply connected injectors. The internal pressure sensor monitors the pressure build-up and venting of the system, and the integrat-

ed vent valve ensures that the mainline pressure is relieved after a lubrication impulse.

Single-line lubrication system

Pump 603S

The pump P603S incorporates an internal connection of the lubricant quantity from one to three pump elements. With a delivery of 4 cm³/min (1.57 inch³/min) for each pump element, sufficient lubricant is available for a supply to the connected metering devices.

The internal pressure switch monitors the pressure build-up and venting in the system, and the internal vent ensures proper relief of the main line during the pause interval.

4-, 8-, 10-, 15- or 20-litre, (1-, 2.1-, 3.9- or 5.3-gallon) reservoir capacity is available. For rotating operation, the reservoir is equipped with a follower plate and stirring paddle. For stationary applications, a stirring and fixed paddle assembly is sufficient.

The P603S pump is easy to install. The pump's internal controller is easy to program and operates any system using Lincoln Centro-Matic grease injectors including SLV, SLV-XL, SL-1, SL-32, SL-33 and QSL.

The innovative design contains the pump, controller, vent valve and pressure switch or transducer conveniently in one unit.



Pump P603S



Lubrication system including pump 603S, QSL and SE1 suction element and used lubricant container

Reliable operation in harsh environments

Equipment that operates in harsh conditions requires regular lubrication to ensure performance. When a bearing or component fails as a result of insufficient lubrication, the result is downtime and losses. The single-line 603S and 653S pumps/systems automatically provide the lubrication points with exact metered quantities in programmed intervals while the equipment is in operation.

As a result, the robust system is ideally suited for wind turbines – even offshore applications.

The metal-to-metal fit of the injector makes them suitable for high pressure. Each injector's output can be individually set. In general, the injector function is visually monitored, but optional electrical monitoring or a GSM controlled system is available.



P603S filling via follower plate

Visual monitoring – to ensure all is well

Each injector has an indicator pin that moves with the pressure buildup and venting. This facilitates easy trouble-shooting when required by simply observing the indicator pins.

Additional pressure switch

An additional pressure switch at the end of larger systems can be used for added pressure control to ensure correct lubrication.

For off-shore systems we offer special corrosion resistant pumps, QSL injectors and suction elements.

Special features for wind turbine applications – also for off-shore systems

Lincoln single-line systems completely vent during the pause interval. As a result, they are suitable for fast separating lubricants.

For rotating operation in wind turbines the reservoir is equipped with a follower plate and stirring paddle – which also facilitates the usage of fast separating lubricants. For stationary operation a stirring and fixed paddle is sufficient.

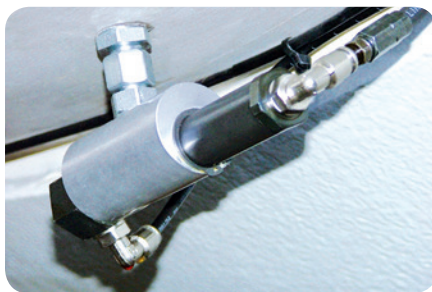
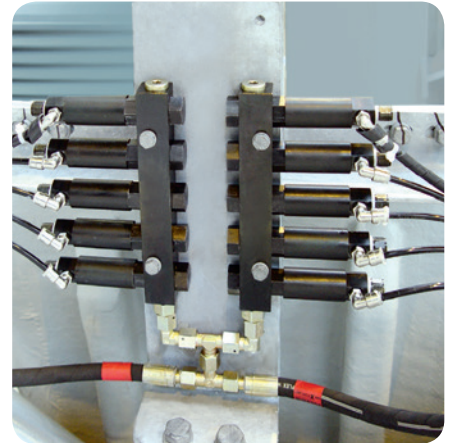

SE1 suction element

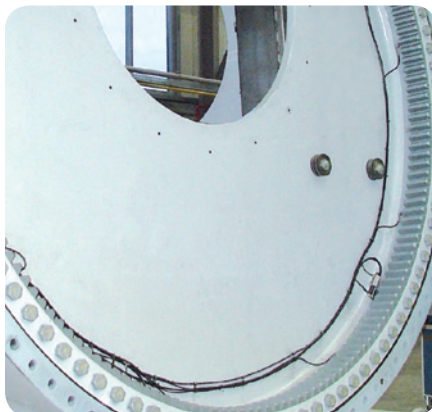

Suction elements

The external suction element SE1 was developed especially for single line lubrication systems in wind turbines to cleanly remove used grease from a bearing. The used lubricant is collected in a used grease container AFB 10 with a 10 litre (2.6 gallon) capacity, and can be reused for the lubrication of pinion gears.

As a result, the problem of used grease in bearings is reduced. The lubricant does not force its way through seals and keeps the area around the bearing clean and safe. Likewise, the recycling of the used grease lessens the environmental impact and conserves resources.

During the pressurization phase, the connected single-line pump P603S transports the pre-metered used lubricant from the bearing via the separate disposal connection to the AFB 10 used lubricant container. When the P603S single-line pump vents, the vacuum created in the suction side pulls in the used lubricant into the metering chamber from where it is transferred during the next pressurization phase.

PU lubrication pinion

Pinion gear

Lincoln has over a century of experience in the lubrication of open gears. For wind turbines Lincoln currently uses a mechanical lubricant application method.

A specially developed lubrication pinion wheel provides a 100% lubricant film to the gear tooth. The new PU pinion only applies lubricant where it is needed, i.e. the spot is on the gear that is under load.

The Lincoln progressive system or single-line system can be used to supply lubricant to the pinion.

An important factor for proper lubrication is the selection of a suitable lubricant that also does not drip off under high temperatures. We will gladly supply you with our comprehensive test results and operation tests for new lubricants.

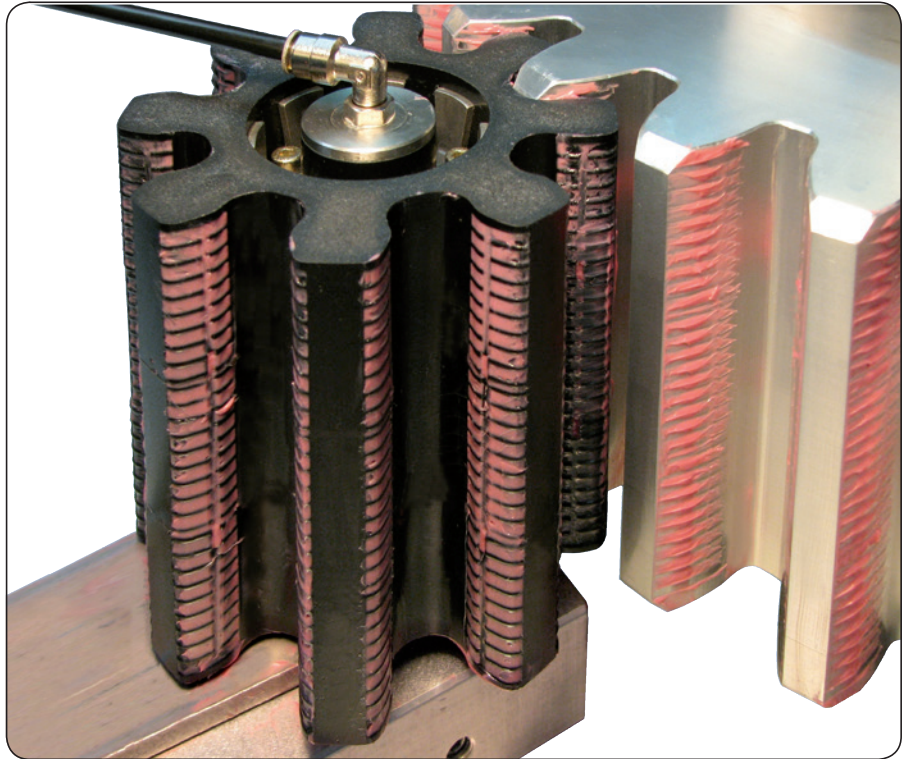

PU lubrication pinion for an even lubricant application

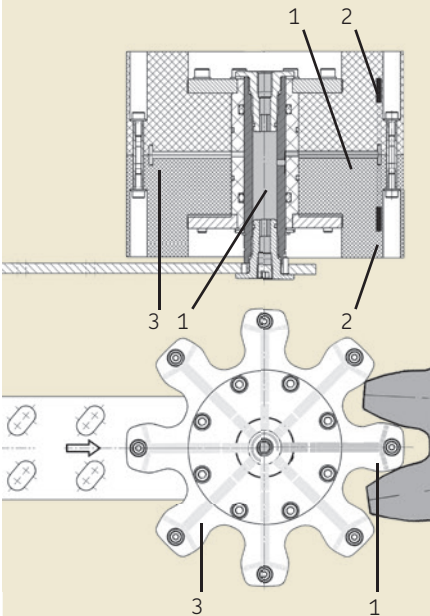

- 1 Lubricant under pressure
- 2 Lubricant discharge on the comb-profile
- 3 Lubricant pressureless

Lubrication pinions are available in different sizes

Module	m10 to m36
Pinion height	80 to 270 mm
Diameter	112 to 220 mm

Technical data

Operating temp.	-30 to +80 °C
Material	Polyurethane PU
Number of teeth	8
Lubricant	NLGI 2
Lubricant connection	1/8 in.

Lubrication tools and equipment

120 V electric PowerLuber¹

New to the PowerLuber family of grease guns, the electric PowerLuber was designed specifically for the wind energy market.

Turbines require large volumes of grease to be dispensed during each lubrication maintenance visit. Tower heights and tight working spaces present unique challenges to maintenance workers.

Cordless guns operate well, but the high grease volume requirements mean frequent battery changes. Hauling multiple batteries to the top of the tower is ineffective and costly.

Unlike any grease gun on the market, this tool provides endless run times and is more energy efficient than air-operated grease guns.

Features

- 2-speed transmission – high volume (medium pressure) or high pressure (standard volume)
- Stroke indicator pin
- Air cooled 120 V motor
- Patented transmission design
- Variable-speed trigger
- Six-foot (1.8 meter) power cord
- 6 500 psi (448.2 bar) pressure-relief valve
- UL approved

¹) for use in North America only



Manual grease filler pump – quick filling

The manual grease filler pump comes with a special adapter for Quicklub pumps. Filling of the pump reservoirs takes just a fraction of the time that would normally be required using conventional manual grease guns.

14.4 V or 18 V PowerLuber

- Two-speed switch for high-pressure or high-volume delivery
- Cycle indicator pin to monitor grease output
- One-hour charging system delivers reliable power

14.4 V or 18 V PowerLuber packed in a heavy-duty compact case moulded from impact- and stain-resistant plastic.

This package comes complete with the 14.4 V or 18 V PowerLuber and battery, a 230 V one-hour charger, and a 760 mm flex hose with spring guard.



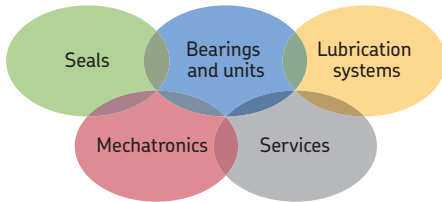

The Power of Knowledge Engineering

Drawing on five areas of competence and application-specific expertise amassed over more than 100 years, SKF brings innovative solutions to OEMs and production facilities in every major industry worldwide. These five competence areas include bearings and units, seals, lubrication systems, mechatronics (combining mechanics and electronics into intelligent systems), and a wide range of services, from 3-D computer modelling to advanced condition monitoring and reliability and asset management systems. A global presence provides SKF customers uniform quality standards and worldwide product availability.

! Important information on product usage

All products from SKF may be used only for their intended purpose as described in this brochure and in any instructions. If operating instructions are supplied with the products, they must be read and followed.

Not all lubricants are suitable for use in centralized lubrication systems. SKF does offer an inspection service to test customer supplied lubricant to determine if it can be used in a centralized system. SKF lubrication systems or their components are not approved for use with gases, liquefied gases, pressurized gases in solution and fluids with a vapor pressure exceeding normal atmospheric pressure (1 013 mbar) by more than 0,5 bar at their maximum permissible temperature.

Hazardous materials of any kind, especially the materials classified as hazardous by European Community Directive EC 67/548/EEC, Article 2, Par. 2, may only be used to fill SKF centralized lubrication systems and components and delivered and/or distributed with the same after consulting with and receiving written approval from SKF.

Lincoln GmbH

Heinrich-Hertz-Str. 2-8
69190 Walldorf
Germany

Tel. +49 (0)6227 33-0
Fax +49 (0)6227 33-259

This brochure was presented by:

© SKF is a registered trademark of the SKF Group.

© Lincoln, Centro-Matic, Quickclub and PowerLuber is a registered trademark of Lincoln Industrial Corp.

© SKF Group 2012

The contents of this publication are the copyright of the publisher and may not be reproduced (even extracts) unless prior written permission is granted. Every care has been taken to ensure the accuracy of the information contained in this publication but no liability can be accepted for any loss or damage whether direct, indirect or consequential arising out of the use of the information contained here in.

PUB LS/P2 13122 EN · November 2012 · FORM W-200-EN-1112

Certain images used under license from Shutterstock.com

